

AC-7 Check Weigher



High Accuracy

No Zero Drift

Dynamic Compensation

100 Product Memory

Application Flexibility

Easy Removal for Cleaning Purpose

Easy Integration with Existing Lines





Applications

Apply range: Used to detect the weight of product whether match with the target weight, meanwhile auto-selecting device picks out the unqualified products.

The Segment where the check weigher could be useful:

Pharmaceutical: Missing Strips, Leaflet's, Tablet, Capsule, proper filling of injectable and vials.

Food/Confectionary: Tea, Coffee, Concentrate, Cheese, Bakery Products.

Components: Missing CD's, Electronics Parts.

Cosmetics: Semi-Filled / Unfilled Tooth Paste in Tube, Talc Bottle

Engineering: Missing Gaskets, Fasteners, High quality of drilling / Machine Tools.

Paper Industry: Missing Paper

Frozen Products: Under weight Meat, Green Salad, Fruits, Vegetable

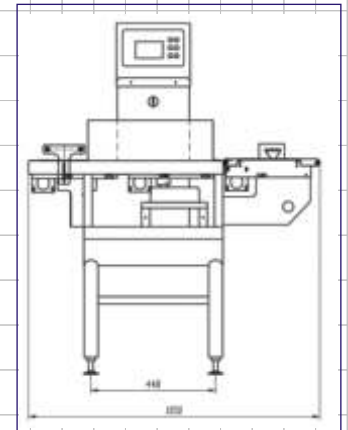
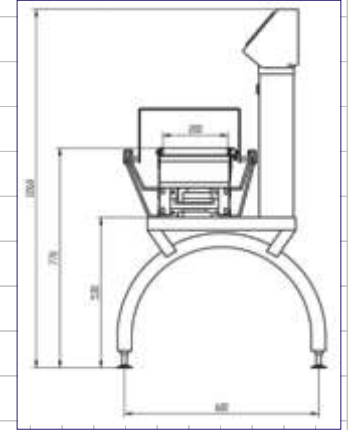

Feather

- Apply advanced digital signal processing and high speed and stable weighing.
- Special frame structure enables keeping accuracy
- Powerful calculation function, can record every checking data.
- Package Size(mm): 1145(L)X860(W)X1440(H)
- G.W: 145 kg

Technical Specifications

Parameter/Model	STANDARD WEIGHT SUBAREA				
	10~99g	100~200g	201~400g	401~999g	1000~10000g
Speed (bags/min)	65	55	50	45	40
Accuracy (g)	± 0.5	± 0.6	± 0.8	± 1	± 2
Minimum Scale (g)	0.1	0.1	0.1	0.1	1
Preliminary Program (Sets)	10	10	10	10	10
Size (mm)	1050 (L) X 681 (W) X 1260 (H)				
Options: Eliminate Device	Blower Device / Reject Device				
Voltage (V)	220V				
Power (watt)	300W				



WORLDWIDE MARKETING:

CITIZEN SCALE (I) PVT. LTD.

231/232, Laxmi Plaza, Bldg., No.9, Laxmi Industrial Estate, New Link Road, Andheri (W), Mumbai - 400 058

Tel.: 26305170 • Fax : 26305176 • E-mail : sales@citizenscales.com • Website : www.citizenscales.com

(Under technical collaboration with CITIZEN SCALE INC. USA)